



DIRECTORS CHAIR SPEC SHEET



THE MOST COMFORTABLE E-Z UP® CHAIR EVER!

NEW COLORS!

FEATURES

- Available Sizes: Standard and Tall
- Lightweight Aluminum Frame Construction
- Herringbone Professional Grade Fabric
- Improved Padded Armrest, Chair Back & Seat
- 225 lbs. (102.1 kg) Plus Weight Rating
- Includes Stylized Protective Carry Bag
- **1 Year Warranty**

EMBROIDERY FONTS

- Type 1 **Brush Script**
- Type 2 **CENTURY**
- Type 3 **HELVETICA BOLD**
- Type 4 **Script M5 Bold**

CUSTOM GRAPHIC OPTIONS

- Embroidery Size Up to 16" Wide and 5" High (40 cm x 13 cm)
- Up to 100,000 Stitches
- Single or Double Sided Script Embroidery

- Up to 2 Lines of Text (Same Font)
- Average Letters Per Line:
 - 2" (5 cm) High, 10 Letters
 - 1" (2.5 cm) High, 21 Letters
- Single or Double-Sided Graphic Imprint

AVAILABLE COLORS



Directors Chair

STANDARD & TALL

The E-Z UP® Directors Chair complements any E-Z UP® portable shelter product set-up. The E-Z UP® Directors Chair has been specially engineered for durability, comfort and stability. Rest E-Z with a plain or imprinted folding Directors Chair.



DIRECTORS CHAIR SPEC SHEET

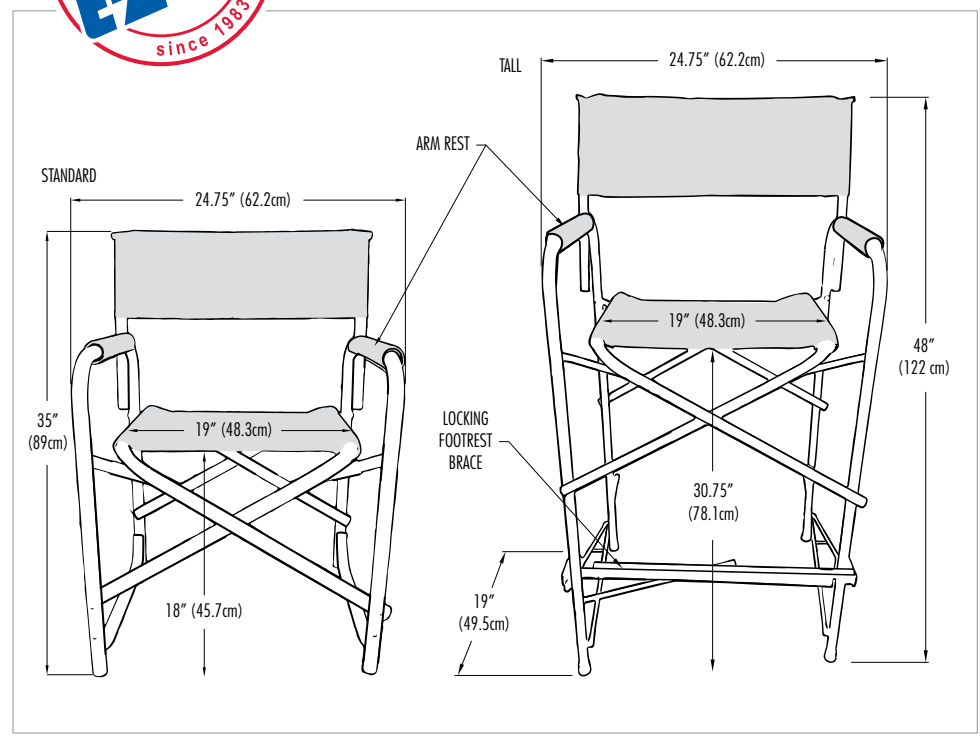

SPECIFICATIONS

SIZE	Standard	Tall
COLOR OPTIONS	Black, Blue, Green, Red, Cyan, White	Black, Blue, Green, Red, Cyan, White
DIMENSIONS	24" (61 cm) Wide, 18" (46 cm) Deep 35" (90 cm) Back Height, 17.5" (44 cm) Seat Height	24" (61 cm) Wide, 18" (46 cm) Deep 48" (1.2 m) Back Height, 31" (79 cm) Seat Height
FRAME	Powder-Coated Aluminum	Powder-Coated Aluminum
FABRIC	Professional Grade Fabric	Professional Grade Fabric
PRODUCT INCLUDES	Chair, Chair Back & Protective Carry Bag	Chair, Chair Back & Protective Carry Bag
ITEM WEIGHT	7.4 lbs. (3.4kg)	9 lbs. (4 kg)
PACKAGE WEIGHT	12 lbs. (5.4kg)	15 lbs. (6.8 kg)
BOX DIMENSIONS	35.25" L x 20" W x 6.25" H (89 cm x 51 cm x 16 cm)	48.5" L x 20" W x 6.25" H (1.2 m x 56 cm x 16 cm)
MAXIMUM WEIGHT LOAD	225 lbs. (102.1 kg)	225 lbs. (102.1 kg)
WARRANTY	1 Year	1 Year

OTHER E-Z UP® INSTANT PRODUCTS...



RECOMMENDED USES

- Event Marketing
- Organizations
- Portable Signage
- Rental Industry
- Personal Services
- Instant Signage
- Business & Civic Events
- Trade Shows
- Commercial Use
- Advertisements
- Corporate Events
- Exhibit Booths

PLACE YOUR DEALER INFORMATION HERE

E-Z UP® products are built better. From the quality of the materials we use, to our best-practice manufacturing processes, an E-Z UP® shelter is built for years of reliable hassle-free use.